

LIMITATORI

TORQUE
LIMITERS



Piazzalunga
MOTION CONTROL TECHNOLOGIES

Friction limiter LF

- Overload control by transmission part slipping
- Friction rings without asbestos
- Excellent in dusty environments
- No noise and vibrations
- Protection in both directions of rotation
- Torque adjustment system with simple precise engagement by means of an adjustable ring nut



ON REQUEST

- Complete with transmission organ (crown, pulley, etc.)
- Friction rings with different compounds for special applications
- With hole and keyway or set up for shrink discs or other locking types
- With anticorrosion surface treatment



LF base modelPage 6



LF/CK overload response signalPage 7



LF/GC with chain couplingPage 8



LF/GS with star couplingPage 9



LF/GE with compact elastic couplingPage 9

TRANSMITTABLE TORQUES

Transmittable torques [Nm] in relation to the configuration of the springs									
ID	A1S1)	A2S2)	A3S3)	A1M1)	A1G1)	A2G2)	A3G3)	ST (())	SQ (())
025	1 - 8	2 - 12	2 - 20						
038	1 - 14	8 - 22	15 - 34						
050	2 - 12				4 - 40	17 - 70	23 - 100	1,5 - 9	
070	6 - 18			9 - 35	19 - 60	34 - 120	60 - 210	2 - 34	2 - 60
090				13 - 105	74 - 140	90 - 280	185 - 450	5 - 56	3 - 70
115				65 - 280	120 - 360	207 - 700	210 - 950	10 - 130	25 - 160
140					180 - 550	260 - 950	390 - 1200		
170					160 - 700	300 - 1450	1000 - 2600		

ID	A4M1 (())	A4G1 (())	A4G2 (())						
205	300 - 1200	500 - 2400	1000 - 4800						
240	500 - 2000	1000 - 4000	2000 - 8000						
300	800 - 3500	1500 - 7000	3000 - 14000						
340	1000 - 4500	2000 - 9000	4000 - 18000						
400	1500 - 5000	3000 - 11000	5000 - 23000						

LF series friction torque limiter



- Overloads from 2 to 23000 Nm
- Hole maximum \varnothing 140 mm

Available with:

- Spiral springs as alternative to standard disc springs
- Customised alignment, interchangeable with competitors' products (distance "L")
- With statically balanced GR type radial ring nut
- Anticorrosion surface treatment

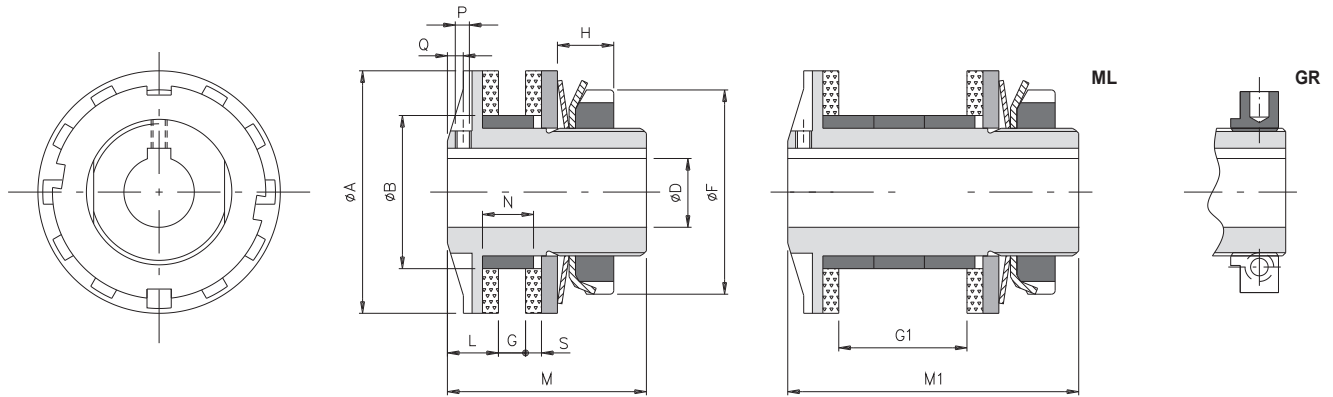

TECHNICAL DATA

ID	MT [Nm]	A	B h7	D H7		F	G		G1	L	M	M1	N	P	Q	S	Rpm Max	Kg	
				Std	Max		Min	Max										Max	/ML
025	1 - 20	25	14	-	8	22	1	3	-	5	26	-	5,5	M3*	3*	2	10000	0,1	-
038	1 - 34	38	24	-	12	32	1	5	21	8	33	46	8	M3	2	2,5	10000	0,2	0,3
050	2 - 100	50	36	-	20	44	1	6	26	10	35	57,5	10	M4	3	3	7600	0,4	0,5
070	6 - 210	70	45	-	25	63	1	10	40	15	55	85	15	M6	4,5	4	5450	1,1	1,4
090	13 - 450	90	60	-	38	82	3	12	46	16	60	95	17	M6	5,5	4	4250	2,2	2,8
115	26 - 950	115	72	18	45	105	5	16	58	18	70	113	21	M6	6	4	3350	3,7	4,8
140	80 - 1200	140	85	24	55	130	8	19	69	20	80	136	25	M8	6	5	2750	6,6	8,5
170	160 - 2600	170	98	28	65	158	10	22	78	22,5	95	153,5	28	M8	6,5	5	2250	10,9	13,5

data not binding

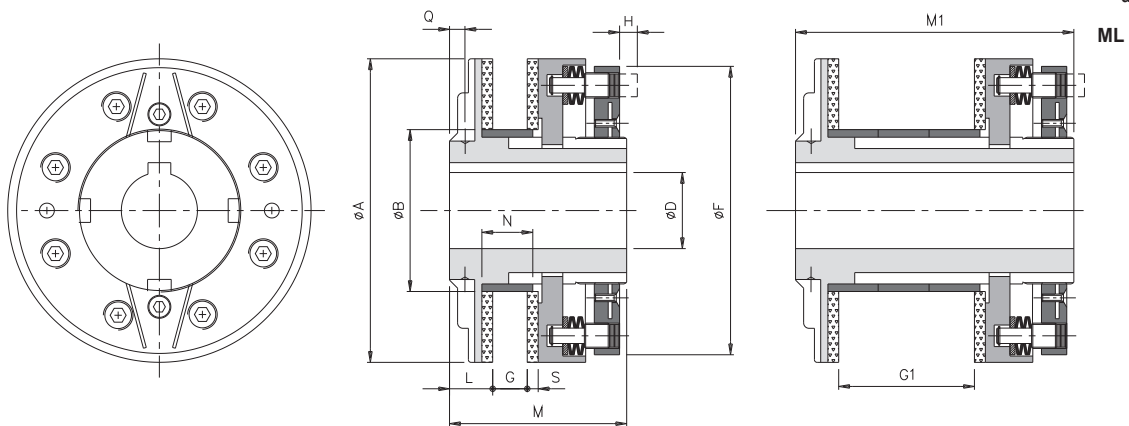

TECHNICAL DATA

ID	MT [Nm]	A	B h7	D H7		F	G		G1	L	M	M1	N	S	On request Q	Rpm Max	Kg	
				Std	Max		Min	Max									Max	/ML
205	300 - 4800	205	120	38	80	193	18	26	90	27	110	174	32	5	8,5 - M8	1900	20,1	24,5
240	500 - 8000	240	145	50	100	230	18	29	99	27	116	186	35	5	8,5 - M10	1600	30,9	37,8
• 300	800 - 14000	300	175	60	120	287	21	33	113	29	123	203	40	6	8,5 - M10	1300	49,1	60,8
• 340	1000 - 18000	340	205	60	130	325	23	33	113	41	158	238	40	6	12 - M12	1200	85,5	102,5
• 400	1500 - 23000	400	230	60	140	388	23	35	119	46	167	251	42	6	13 - M12	1000	124,5	147,7

• On request

data not binding

NOTES

P-Q*: on the Gr.025 the hole for grub screw is made on the side of the ring nut instead of the flange side.

Technical details: the weights refer to the torque limiter (LF) pilot bore.

LF/CK model with overload response signal



- Overloads from 3 to 23000 Nm
- Hold maximum \varnothing 140 mm
- Overload response signal
- Automatic re-engagement

Available with:

- Long hub
- Friction rings with different compounds for special applications
- Spiral springs as alternative to standard disc springs

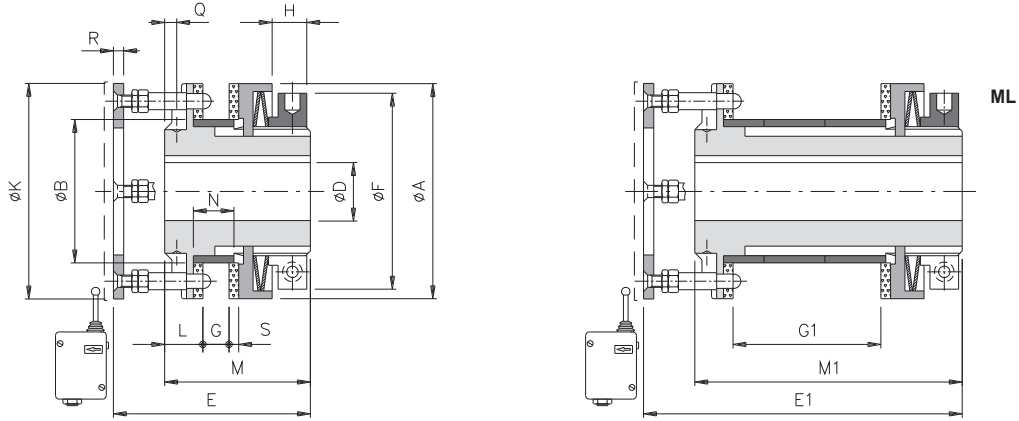

TECHNICAL DATA

ID	MT [Nm]	A	B h7	D H7		E	E1	F	G		G1	K	L	M	M1	N	R	S	On request Q	Rpm Max	Kg	
				Std	Max				Min	Max											Max	/ML
070	6 - 210	70	45	-	25	75	105	63	5	10	40	70	15	55	85	15	3	4	4,5 - M4	5450	1,4	1,7
090	13 - 450	90	60	-	38	80	114	82	7	12	46	90	16	61	95	17	3	4	5 - M6	4250	2,7	3,3
115	26 - 950	115	72	18	45	89	131	104	9	16	58	115	18	71	113	21	4	4	5 - M6	3350	4,9	6,0
140	80 - 1200	140	85	24	55	103	153	128	13	19	69	140	20	86	136	25	4	5	6 - M6	2750	7,8	9,7
170	160 - 2600	170	98	28	65	116	172	157	15	22	78	170	22,5	97,5	153,5	28	4	5	6,5 - M8	2250	12,9	15,5

data not binding

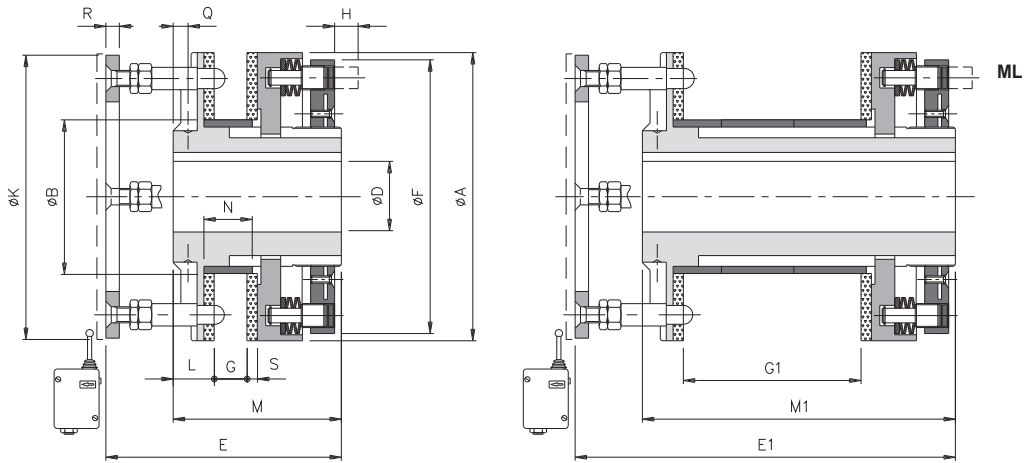

TECHNICAL DATA

ID	MT [Nm]	A	B h7	D H7		E	E1	F	G		G1	K	L	M	M1	N	R	S	On request Q	Rpm Max	Kg	
				Std	Max				Min	Max											Max	/ML
205	300 - 4800	205	120	38	80	125	189	193	18	26	90	205	27	110	174	32	4	5	8,5 - M8	1900	20,9	25,2
240	500 - 8000	240	145	50	100	131	201	230	18	29	99	240	27	116	186	35	6	5	8,5 - M10	1600	32,2	39,1
300	800 - 14000	300	175	60	120	136	216	287	21	33	113	300	29	123	203	40	6	6	8,5 - M10	1300	50,6	62,3
340	1000 - 18000	340	205	60	130	172	252	325	23	33	113	340	41	158	238	40	6	6	12 - M12	1200	88	105
400	1500 - 23000	400	230	60	140	176	260	388	23	35	119	400	46	167	251	42	6	6	13 - M12	1000	128,8	152

• On request

data not binding

NOTES

Technical characteristics: the weights refer to the torque limiter (LF/CK) pilot bore.

LF/GC series model with chain coupling

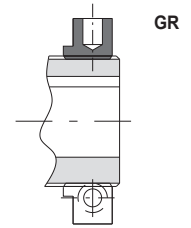
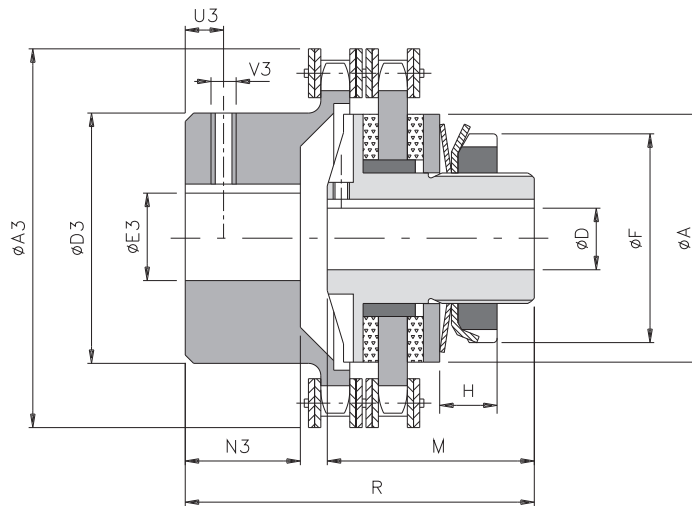

TECHNICAL DATA

ID	MT [Nm]	A	D H7		F	M	R	A3	D3	E3 H7		N3	U3	V3	Rpm Max	Kg
			Std	Max						Std	Max					
025	1 - 20	25	-	8	22	26	39	45	23	8	12	9	4	M3	5000	0,2
038	1 - 34	38	-	12	32	33	58	57	37	10	20	20	5	M3	5000	0,6
050	2 - 100	50	-	20	44	35	58	75	50	12	28	19	8	M4	3800	1,1
070	6 - 210	70	-	25	63	55	87	101	70	16	38	29	12	M6	2800	2,8
090	13 - 450	90	-	38	82	60	102	126	89	20	55	38	12	M6	2200	5,9
115	26 - 950	115	18	45	105	70	131	159	112	20	70	56,5	15	M8	1800	11,1
140	80 - 1200	140	24	55	130	80	145	184	130	28	80	59,5	15	M8	1500	20,3
170	160 - 2600	170	28	65	158	95	189	215	130	30	80	88	15	M8	1300	31,0

data not binding

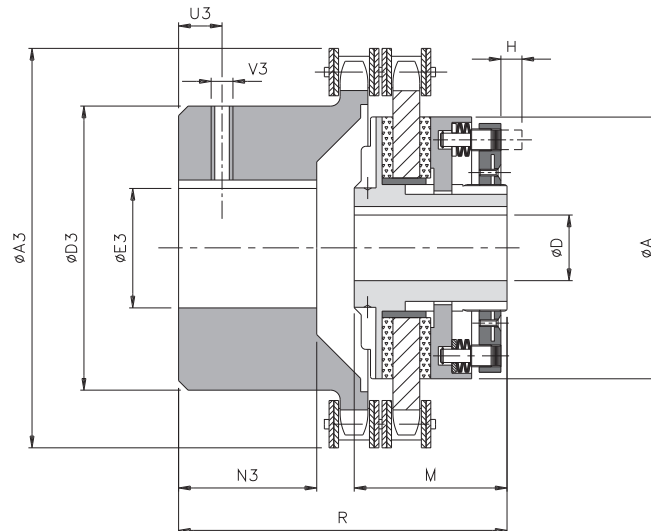

TECHNICAL DATA

ID	MT [Nm]	A	D H7		M	R	A3	D3	E3 H7		N3	U3	V3	Rpm Max	Kg
			Std	Max					Std	Max					
205	300 - 4800	205	38	80	110	218	291	150	38	90	103	25	M10	1000	54,6
240	500 - 8000	240	50	100	116	245	310	170	50	110	124	25	M10	900	76,7
• 300	800 - 14000	300	60	120	123	284	374	200	50	140	147	30	M12	700	125,5
• 340	1000 - 18000	340	60	130	158	329	423	210	60	150	165	30	M12	600	180
• 400	1500 - 23000	400	60	140	167	364	471	240	60	160	191	30	M16	500	260

• On request

data not binding

NOTES

Technical characteristics: the data given refers to the complete unit (LF/GC).

Technical characteristics: the weights refer to the complete unit (LF/GC) pilot bore.

LF/GS series model with star coupling

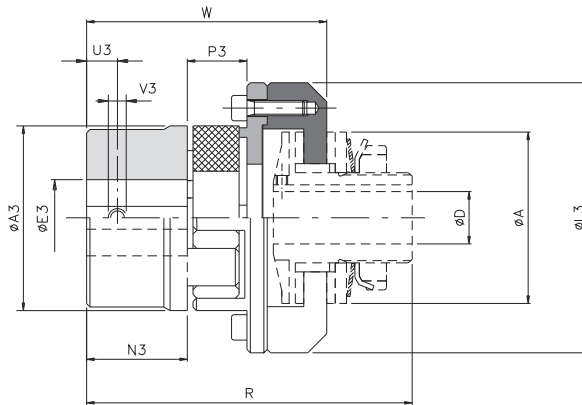

TECHNICAL DATA

ID	MT [Nm]		A3	E3 H7 Max	L3	N3	P3	U3	V3	D H7		R	W	Misalignments			Rpm Max	Kg
	Nom	Max								Std	Max			Angular α [°]	Axial X [mm]	Radial K [mm]		
025	12,5	25	30	16	43	11	12	5	M4	-	8	56	37,5	0°54'	1	0,09	10000	0,2
038	17	34	40	25	58	25	16	10	M5	-	12	84,5	64	1° 18'	1	0,20	10000	0,4
050	60	120	55	35	74	30	18	10	M5	-	20	94	74,5	1° 18'	1	0,22	7600	0,8
070	325	650	80	48	107	45	24	15	M8	-	25	135	104	1° 18'	1,4	0,28	5450	3,3
090	450	900	95	55	132	50	26	20	M8	-	38	148,5	115,5	1° 18'	1,6	0,32	4250	5,4
115	685	1370	120	74	164	65	30	20	M10	18	45	181,5	143,5	1° 18'	1,8	0,38	3350	10,3
140	1465	2930	160	95	208	85	40	25	M10	24	55	224	181	1° 18'	2,5	0,48	2750	21,1
170	3600	7200	200	110	246	100	45	30	M12	28	65	260	207,5	1° 18'	2,8	0,50	2250	36,3
205	3300	6600	225	115	285	110	50	30	M12	38	80	295	236	1° 18'	3,0	0,52	1900	-
240	4800	9600	255	125	330	120	55	33	M16	50	100	317	255	1° 18'	3,2	0,55	1600	-

• On request

data not binding

LF/GE series model with compact elastic coupling

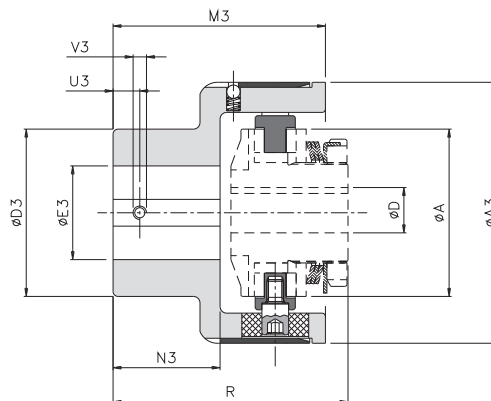

TECHNICAL DATA

ID	MT [Nm]		A3	D3	E3 H7		M3	N3	U3	V3	A	D H7		R	Misalignments			Rpm Max	Kg
	Nom	Max			Std	Max						Std	Max		Angular α [°]	Axial X [mm]	Radial K [mm]		
038	35	50	63	42	5	20	60,5	29	8	M4	25	-	12	58	1°	±0,7	0,5	6000	0,8
050	70	110	78	50	10	28	63,5	32	10	M5	50	-	20	68	1°	±0,7	0,5	5500	1,41
070	280	420	108	70	12	38	89	49	12	M6	70	-	25	106	0° 48'	±0,7	0,5	5000	4,18
090	570	860	130	80	15	45	111	65	15	M8	90	-	38	128	0° 36'	±0,7	0,6	4250	7,45
115	980	1500	161	100	15	60	140	85	15	M8	115	18	45	158	0° 30'	±0,8	0,6	3350	13,4
140	2340	3600	206	120	20	70	168	105	20	M10	140	24	55	189,5	0° 24'	±0,8	0,6	2750	24,1
170	3880	5800	239	135	30	80	201	130	20	M10	170	28	65	229,5	0° 24'	±0,8	0,6	2250	37,9
205	15000	20000	315	215	40	150	260	165	25	M12	205	38	80	290,5	0° 24'	±0,8	0,6	1900	86,8
240	30000	35000	360	240	40	160	310	205	25	M12	240	50	100	341,5	0° 24'	±0,8	0,6	1500	160,5

• On request

data not binding

NOTES

... + GS (misalignments)*: the data refers to the normal red star 98 Sh-A.

Technical characteristics: the data and weights given refer only to the application (GS/GE), for the data of the torque limiter see page 7.

**EDT-S100
Pulegge**



**GDP-GD-GDS-GSTR
Giunti**



**SL-SMP-SX-SS-SC-SA
Slitte**



Limitatori



**MINI
Pulegge**



**BES
Variatori**



**GVBE
Variatori**



**TXR
Pulegge**



**ES-RV
Pulegge**



Piazzalunga
MOTION CONTROL TECHNOLOGIES